

NOTES:  
 1. DIMS IN INCHES  
 2. QTY: 1

TITLE:		FINAL ASSEMBLY		
DRAWN		LUCAS GUSMAN		
DESIGNED		LUCAS GUSMAN		
SIZE	DWG. NO.	REV		
A	EML2322L-A-1	C		
SCALE: 1:6		SHEET 1 OF 7		

DIMENSION TYPE	PLACES IN DIMENSION		
	0.0	0.00	0.000
LOCATIONAL	±0.050	±0.020	±0.005
ANGULAR	±5	±2	±0.5

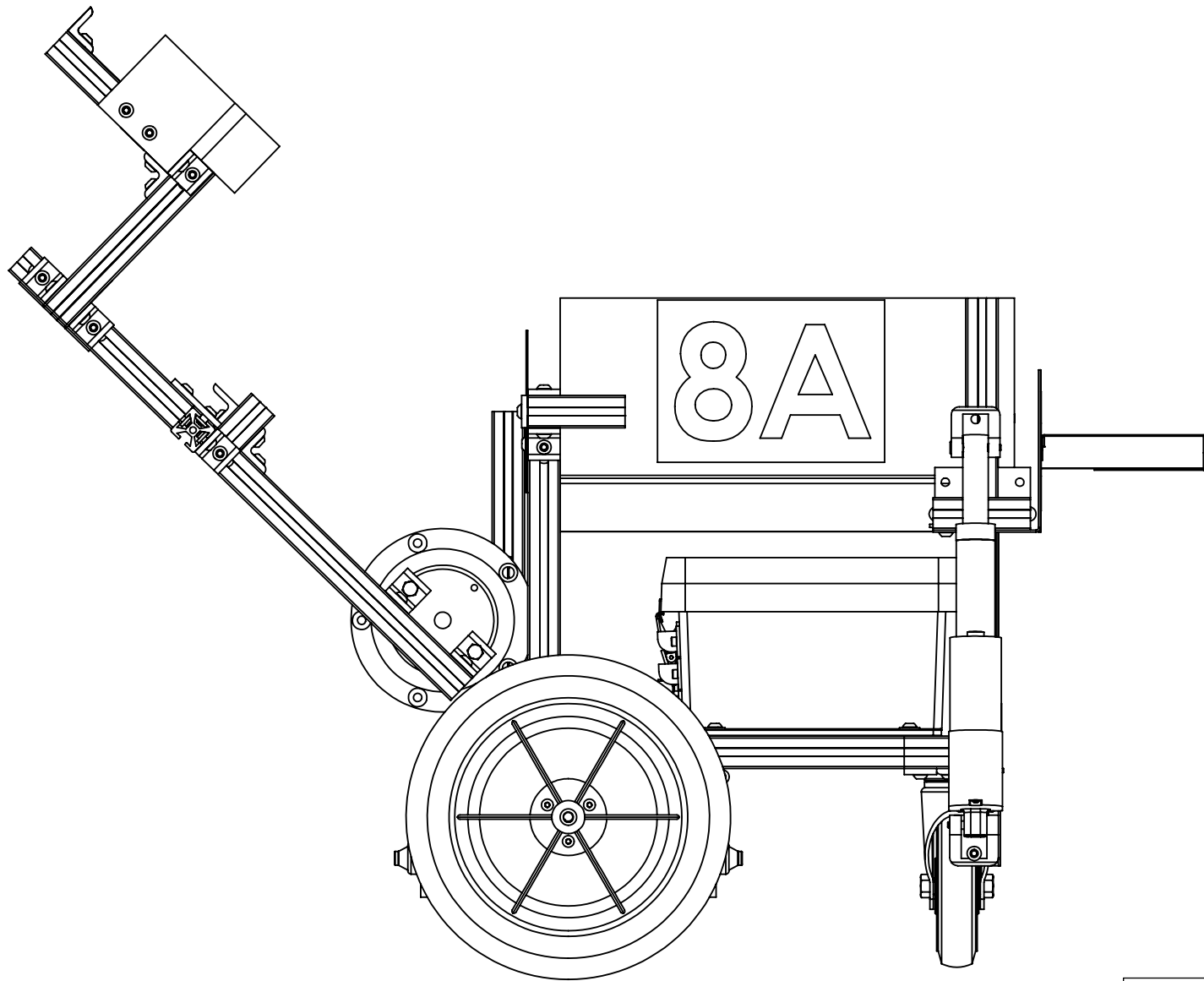

NOTES:  
 1. DIMS IN INCHES  
 2. QTY: 1

TITLE:		FINAL ASSEMBLY		
DRAWN		LUCAS GUSMAN		
DESIGNED		LUCAS GUSMAN		
SIZE	DWG. NO.	REV		
A	EML2322L-A-1	C		
SCALE: 1:5	SHEET 2 OF 7			

DIMENSION TYPE	PLACES IN DIMENSION		
	0.0	0.00	0.000
LOCATIONAL	±0.050	±0.020	±0.005
ANGULAR	±5	±2	±0.5

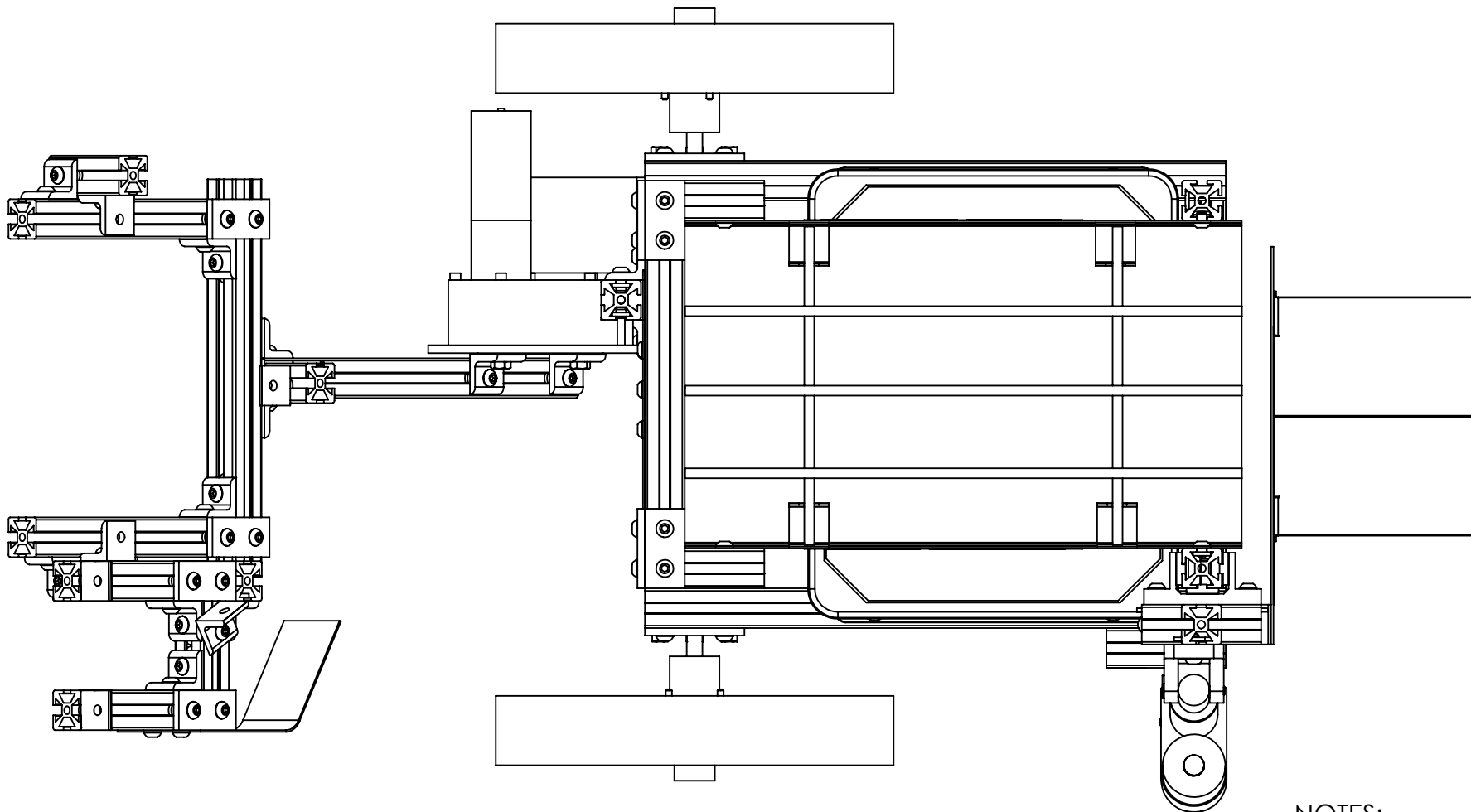

NOTES:  
 1. DIMS IN INCHES  
 2. QTY: 1

TITLE:		FINAL ASSEMBLY		
DRAWN		LUCAS GUSMAN		
DESIGNED		LUCAS GUSMAN		
SIZE	DWG. NO.	REV		
A	EML2322L-A-1	C		
SCALE: 1:4		SHEET 3 OF 7		

DIMENSION TYPE	PLACES IN DIMENSION		
	0.0	0.00	0.000
LOCATIONAL	±0.050	±0.020	±0.005
ANGULAR	±5	±2	±0.5

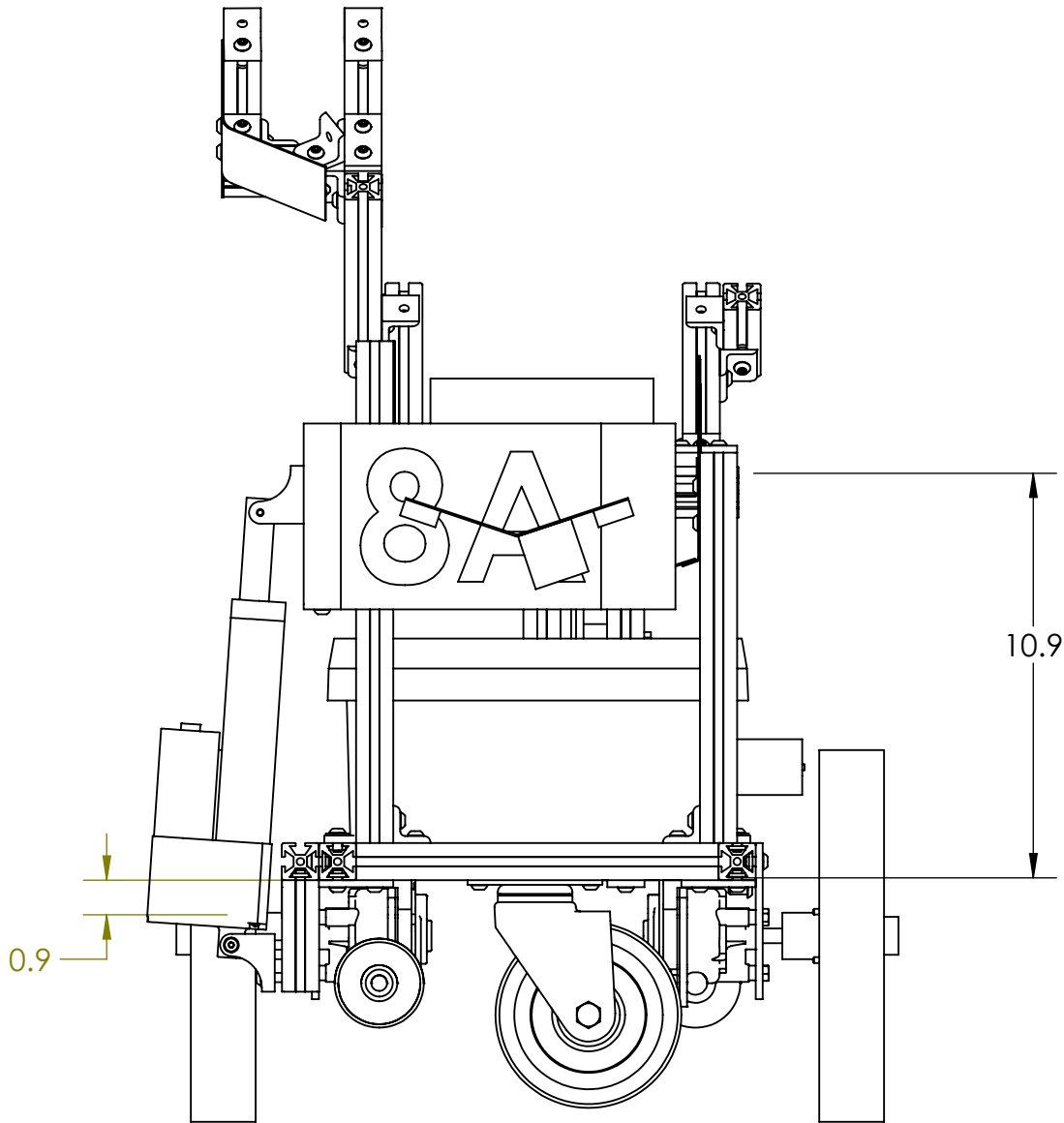

NOTES:  
 1. DIMS IN INCHES  
 2. QTY: 1

TITLE:				FINAL ASSEMBLY		
DRAWN				LUCAS GUSMAN		
DESIGNED				LUCAS GUSMAN		
DIMENSION TYPE		PLACES IN DIMENSION		SIZE	DWG. NO.	REV
		0.0	0.00	A	EML2322L-A-1	C
LOCATIONAL		±0.050	±0.020			
ANGULAR		±5	±2	SCALE: 1:5		SHEET 4 OF 7

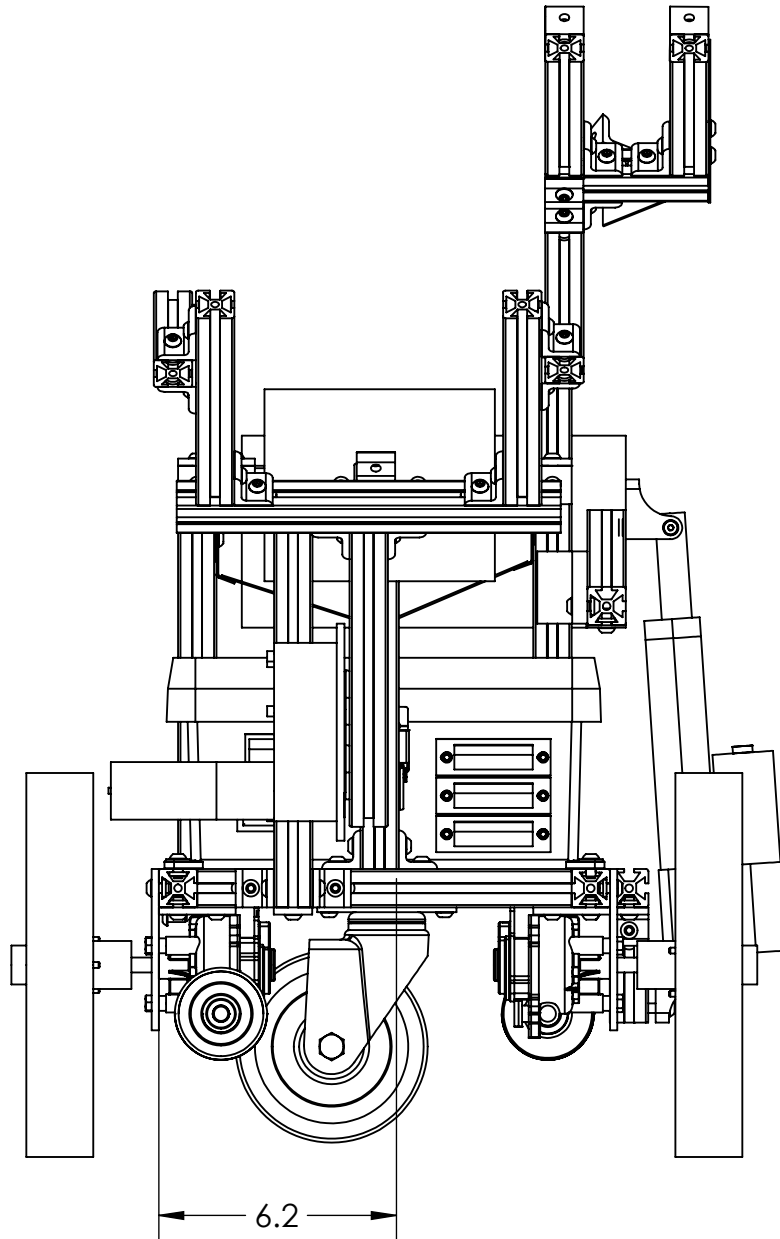

NOTES:  
 1. DIMS IN INCHES  
 2. QTY: 1

TITLE:		FINAL ASSEMBLY		
DRAWN		LUCAS GUSMAN		
DESIGNED		LUCAS GUSMAN		
SIZE	DWG. NO.	REV		
A	EML2322L-A-1	C		
SCALE: 1:5		SHEET 5 OF 7		

DIMENSION TYPE	PLACES IN DIMENSION		
	0.0	0.00	0.000
LOCATIONAL	±0.050	±0.020	±0.005
ANGULAR	±5	±2	±0.5

5

4

3

2

1

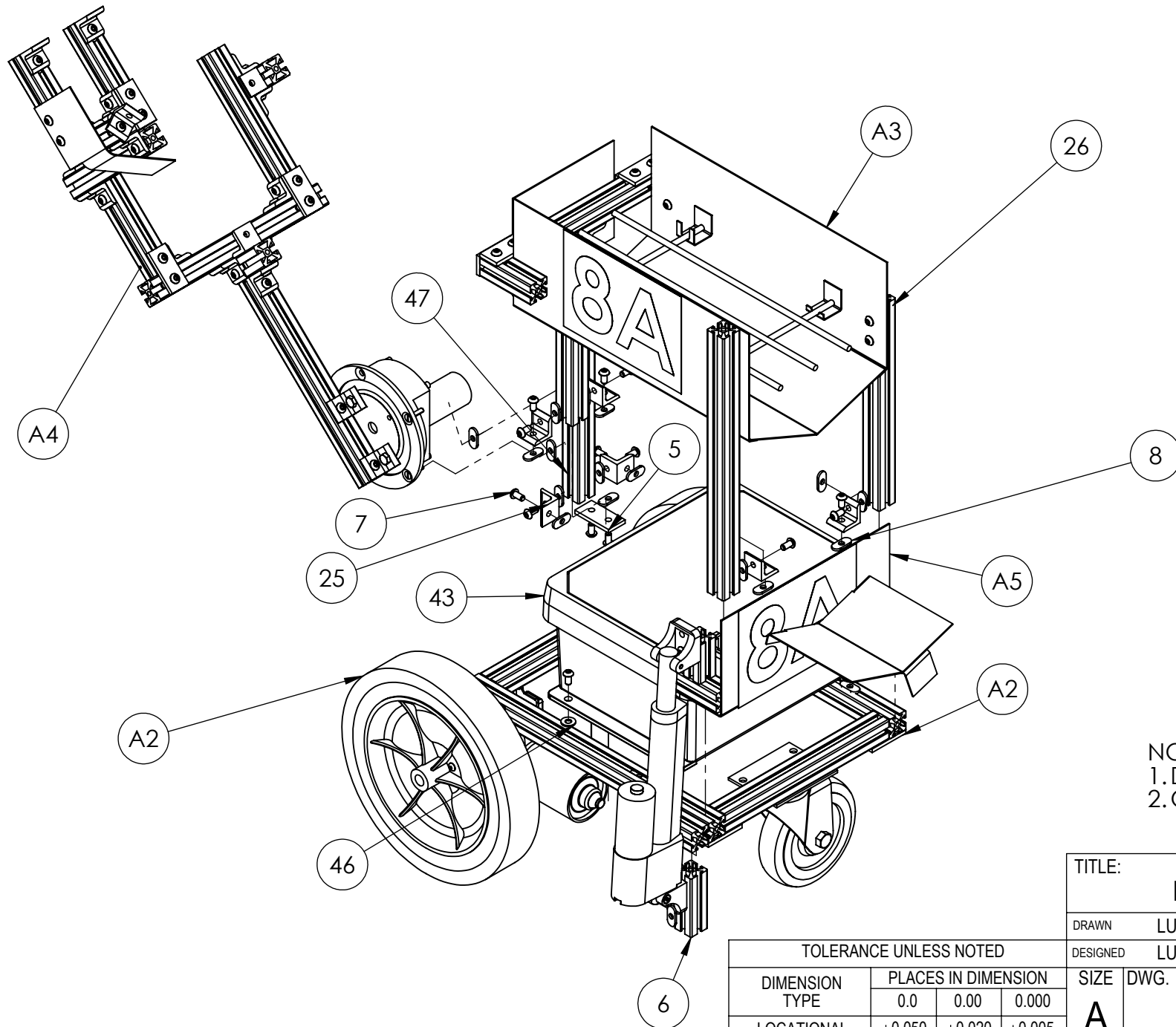

NOTES:  
 1. DIMS IN INCHES  
 2. QTY: 1

TITLE:					FINAL ASSEMBLY		
DRAWN					LUCAS GUSMAN		
DESIGNED					LUCAS GUSMAN		
DIMENSION TYPE		PLACES IN DIMENSION			SIZE	DWG. NO.	REV
		0.0	0.00	0.000			
LOCATIONAL		±0.050	±0.020	±0.005	A	EML2322L-A-1	C
ANGULAR		±5	±2	±0.5			
SCALE: 1:6							SHEET 6 OF 7

TOLERANCE UNLESS NOTED				
DIMENSION TYPE	PLACES IN DIMENSION			
	0.0	0.00	0.000	
LOCATIONAL	±0.050	±0.020	±0.005	
ANGULAR	±5	±2	±0.5	

ITEM NO.	PART NUMBER	DESCRIPTION	Bucket Manipulator Up/QTY.
5	EML2322L-OTS13	80/20 Straight Bracket	1
6	EML2322L-004	80/20 Extrusion - 3.0 inch	1
7	EML2322L-OTS7	1/4-20 X 1/2 inch BHCS	21
8	EML2322L-A-10	1/4-20 T-Nut	23
25	EML2322L-OTS12	80/20 90 Degree Angle Bracket	7
43	EML2322L-OTS1	Control Box	1
46	EML2322L-037	1/4 Washers	4
47	EML2322L-034	80-20 Extrusion - 12.0 inch	1
A2	EML2322L-A-2	Mobile Platform Assembly	1
A3	EML2322L-A-3	Hopper Assembly	1
A4	EML2322L-A-4	Bucket Manipulator Assembly	1
A5	EML2322L-A-5	Release Assembly	1

NOTES:  
1. DIMS IN INCHES  
2. QTY: 1

TITLE:				FINAL ASSEMBLY		
DRAWN				LUCAS GUSMAN		
DESIGNED				LUCAS GUSMAN		
DIMENSION TYPE		PLACES IN DIMENSION		SIZE	DWG. NO.	REV
		0.0	0.00	0.000	A	EML2322L-A-1
LOCATIONAL		±0.050	±0.020	±0.005		
ANGULAR		±5	±2	±0.5		
SCALE: 1:6				SHEET 7 OF 7		

TOLERANCE UNLESS NOTED			
DIMENSION TYPE	PLACES IN DIMENSION		
	0.0	0.00	0.000
LOCATIONAL	±0.050	±0.020	±0.005
ANGULAR	±5	±2	±0.5